

February-2023

# Electronation

Be the best version of you

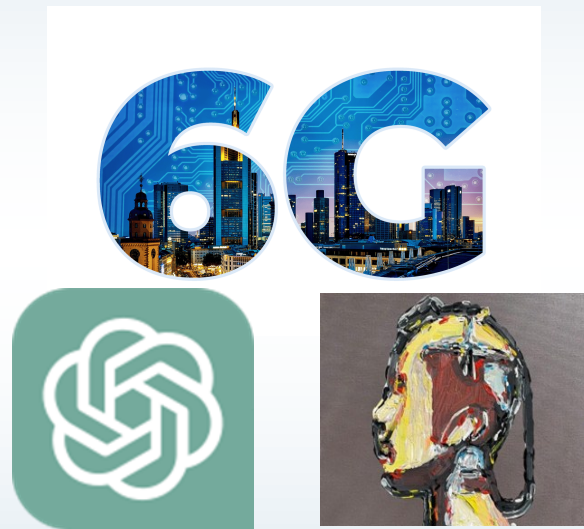

SNJB's Late Sau. Kantabai Bhavarlalji Jain  
College of Engineering , Chandwad  
(Accredited with NAAC 'A' Grade)

**Editor**  
**Prof. K.S Sagale**

**Co-editor**  
**Mr. Vivek Pawar**  
**Mr. Yash Sonar**

## **Department of E&TC Engineering**

### **Vision of the Department**

To prepare Electronics & Telecommunication engineers for the benefit of the society.

### **Mission of the Department**

M1 To provide quality education to students.

M2 To enrich the skill in collaboration with industry for better career opportunity.

M3 To inculcate ethics, values and environment awareness

### **Program specific outcomes**

- PSO1 Apply their skills in designing, implementing and testing electronic systems.
- PSO2 Demonstrate proficiency in use of modern electronic design automation (EDA) tools.
- PSO3 Communicate and work effectively as individuals and as team members.

### **Program Educational Objectives**

PEO1: Have a successful professional career in Electronic and Communication Engineering and related fields.

PEO2: Apply the knowledge of electronics engineering to solve challenges faced by industry and nation.

PEO3: Demonstrate leadership qualities with professional and ethical practices.

PEO4: Adopt to changing professional and societal needs and Engage in lifelong learning.

## Index

Sr.No	Title	Pg.No
01	5G In India	07
02	Sensors and Actuators in IoT Enabling Industrial Automation	10
03	Emerging technologies	12
04	Automatic Height Measurement	16
05	The 5 next trends in electronics	18
06	External Power Adapters and Chargers: An overview of market trends and forecasts	22
07	Importance Of Electronics In Modern Life	24
08	Best Educational Tool	25
09	Cyber Security and Challenges	28
10	Android Smartphones in India Differ From the Rest of the World	31
11	6G Networks: What You Need to Know	32
12	E-Document Diary For College	33
13	Robot creates physical paintings without Human Input	37
14	E-Health Monitoring System	38
15	Flying Cars	42
16	Robot Vacuum Cleaner	44
17	Software-Defined Networking	46

## 5G In India

While voice communications by radio have a long history, mobile phone service as we know it is only about four decades old. The mobile phone network has kept pace with these technological. Several countries have started trialing the 5th Generation (5G), the latest iteration of mobile telephony. It promises to deliver several features that will unlock a host of new usecases.

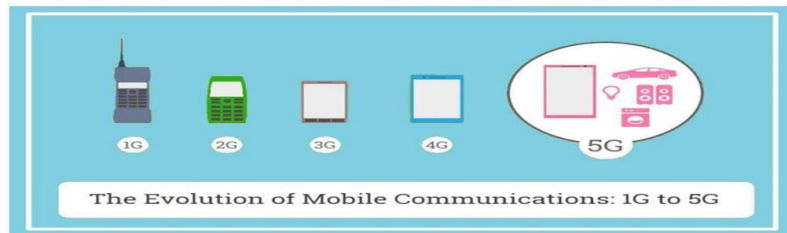
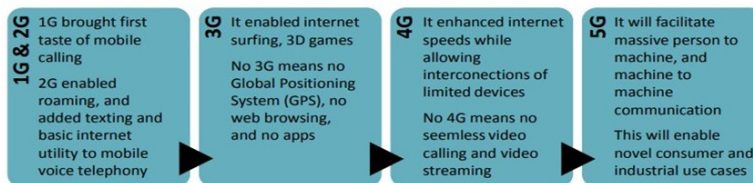
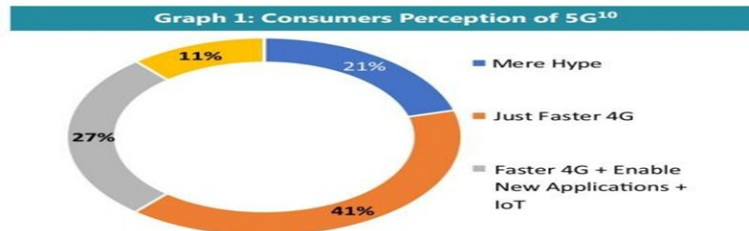

Figure 1: Enhanced Utility for Consumers with Each Generation Upgrade



### Use Cases of 5G:

5G is all about Enhanced Speed The technological superiority of 5G promises lightning-fast internet speed with reduced latency, acting as an enabler for some use cases of 5G. Viewed from a consumer's perspective, the technological evolution from 3G to 4G was marked noticeably by enhanced speed and consequently improved the internet experience of consumers. 4G managed to improve the speed and latency over 3G and thereby amplified the quality of services that 3G had already begun facilitating such as video calling and streaming. being expected from 5G, i.e. The survey checked whether the same impression continues to shape consumer's imagination as to what benefits 5G is likely to bring.



It has been widely believed that 5G enabled services are around the corner, and may become available soon in India. Headlines claiming 5G being rolled out in select cities have already made the news.<sup>21</sup> Exciting announcements have been made by companies such as OnePlus, Samsung, Huawei, etc., pertaining to launching processors for smartphones with support for 5G connectivity. Recently launched India's first 5G enabled phone named X50Pro.<sup>23</sup> This has further echoed the buzz of 5G being launched in India.

### 5G Beneficial for India

5G High-Level Forum titled 'Making India 5G Ready', as prepared by the steering committee constituted by the DoT, which also added that 5G deployment strategy faces conflicting considerations. If we go for early adoption, the equipment is likely to be more expensive, and being early, it will also be glitchy needing costly maturing. On the other hand, early adoption will fast track the country's embrace of 5G's benefits and increase opportunities to develop innovative use cases that support Indian needs. Balancing these conflicts needs to study.

The Indian mobile phone market has largely been dominated by feature phones.<sup>53</sup> It was only in end 2018 that India's smartphone<sup>54</sup> market equaled that of feature phones. <sup>55</sup> Notably, feature phones are still relying on 2G mobile technology. Industry experts also subscribe to the view of 2G feature phones staying in the Indian market, due to their inexpensiveness.<sup>56</sup> Safe to say, that 5G replacing any previous technology, seems a tall order from the near future.

### Setting-up of 5G Antennas and Towers May Take Time

To facilitate reasonable coverage, 5G service providers would have to build 5G antennas and towers extensively. Also, 5G technology demands that



these be very close to users, as opposed to its predecessor technologies. The entire process is not only time consuming but expensive as well, making its reach unevenly spread across geographies. Due to such barriers, even after the initial launch of 5G in the country, consumers are expected to mostly be availing of the coexisting 4G services, even on a 5G enabled handset, in a 5G enabled city. expecting 5G to wipe out 4G completely and fast may not be a sound economic idea. Since LTE was not a backward-compatible technology, a lot of investment has had to be made and is still being made for setting up the 4G infrastructure. This investment would be justified only if the telecom companies can reap the benefits of the infrastructure. 5G NR is expected to coexist with LTE. The coexistence of LTE and NR was also a 3GPP Release 15 work item. for this, several coexistence techniques have been proposed and are under consideration. 4G base station sites are expected to support 5G NR in managing the coverage issues.



**Shradhha Anarthe**  
**BE E&TC**

## **Sensors and Actuators in IoT Enabling Industrial Automation**

In IoT, automation is enabled by connecting data to a machine. Sensors and actuators in IoT represent these two end points of the system. The Internet of Things is a major contributing factor of the new Data Economy. The value of an IoT system goes beyond the original intended use case, for instance in automation. This is because further value lies in the intelligence that an IoT system creates. Sensors are the source of IoT data. Furthermore, sensors and actuators in IoT can work together to enable automation at industrial scale. Finally, analysis of the data that these sensors and actuators produce can provide valuable business insights over time. Driven by new innovations in materials and nanotechnology, sensor technology is developing at a never before seen pace, with a result of increased accuracy, decreased size and cost, and the ability to measure or detect things that weren't previously possible. In fact, sensing technology is developing so rapidly and becoming so advanced that we will see a trillion new sensors deployed annually within a few years.

### **Sensors**

A better term for a sensor is a transducer. A transducer is any physical device that converts one form of energy into another. So, in the case of a sensor, the transducer converts some physical phenomenon into an electrical impulse that determines the reading. A microphone is a sensor that takes vibrational energy (sound waves), and converts it to electrical energy in a useful way for other components in the system to correlate back to the original sound. Actuators Another type of transducer that you will encounter in many IoT systems is an actuator. In simple terms, an actuator operates in the reverse direction of a sensor. It takes an electrical input and turns it into physical action. For instance, an electric motor, a hydraulic system, and a pneumatic system are all different types of actuators.

### **The Importance of Accurate Sensors**

Imagine that you are a bar owner and you want to measure the amount of beer coming out of one of your taps.



To send a stream of electrical impulses to a computer. The computer will interpret the impulses to determine how much beer is flowing through. Sounds simple, right? This is where sensors get interesting. If you look back at our description, you'll see that we never directly measured the amount of beer flowing through the sensor; we interpreted it from a stream of electrical impulses. That means that we must first figure out how to interpret it.

### **Sensor Calibration**

To calibrate the sensor, we'd have to take a container with a known carrying capacity, say, a pint glass. Then we'd have to fill that container under a variety of conditions to determine what the electrical pulse signal looked like. Then, monitor the actuator that is responsible to turn on and off the flow on the other end. For instance, the first pour off a new keg might tend to have more foam, which would read differently than a pour from the middle of the keg that was all beer. It's only through repeated trials and a lot of data that we gain the confidence of interpreting the data. Sensors and actuators in IoT can work together to automate processes, such as filling bottle.





## Emerging technologies

Emerging technologies are technologies whose development, practical applications, or both are still largely unrealized. These technologies are generally new but also include older technologies finding new applications. Emerging technologies are characterized by relatively fast growth, coherence, prominent impact, and uncertainty and ambiguity. Its most prominent impact, however, lies in the future and so in the emergence phase is still somewhat uncertain and ambiguous. Technology today is evolving at a rapid pace, enabling faster change and progress, causing an acceleration of the rate of change. However, it is not only technology trends and emerging technologies that are evolving, a lot more has changed this year due to the outbreak of COVID-19 making IT professionals realize that their role will not stay the same in the contactless world tomorrow. And an IT professional in 2023-24 will constantly be learning, unlearning, and relearning (out of necessity if not desire). Artificial intelligence will become more prevalent in 2023 with natural language processing and machine learning advancement. Artificial intelligence can better understand us and perform more complex tasks using this technology. It is estimated that 5G will revolutionize the way we live and work in the future. Listed Below Are the Top New Technology Trends: 1) Artificial Intelligence 2) Computing Power 3) Quantum Computing 4) Internet Of Things 5) Cyber Security But here, we discuss only Artificial Intelligence.

### **But here, we discuss only Artificial Intelligence**

Artificial Intelligence or AI, has already received a lot of buzz in the past decade, but it continues to be one of the new technology trends because of its notable effects on how we live, work and play are only in the early stages. AI is already known for its superiority in image and speech recognition, navigation apps, smartphone personal assistants, ride-sharing apps and so much more. Other than that AI will be used further to analyze interactions to determine underlying connections and insights, to help predict demand for services like hospitals enabling authorities to make better decisions about resource utilization, and to detect the changing patterns of customer behaviour by analyzing data in near real-time, driving revenues and enhancing personalized experiences.

The AI market will grow to a \$190 billion industry by 2025 with global spending on cognitive and AI systems reaching over \$57 billion in 2023.

ranging from over \$1,25,000 per year (machine learning engineer) to \$145,000 per year (AI architect)

Artificial intelligence (AI), the ability of a digital computer or computer-controlled robot to perform tasks commonly associated with intelligent beings. The term is frequently applied to the project of developing systems endowed with the intellectual processes characteristic of humans, such as the ability to reason, discover meaning, generalize, or learn from past experience. Since the development of the digital computer in the 1940s, it has been demonstrated that computers can be programmed to carry out very complex tasks—as, for example, discovering proofs for mathematical theorems or playing chess—with great proficiency. Still, despite continuing advances in computer processing speed and memory capacity, there are as yet no programs that can match human flexibility over wider domains or in tasks requiring much everyday knowledge. On the other hand, some programs have attained the performance levels of human experts and professionals in performing certain specific tasks, so that artificial intelligence in this limited sense is found in applications as diverse as medical diagnosis, computer search engines, and voice or handwriting recognition.

AI is important because it can give enterprises insights into their operations that they may not have been aware of previously and because, in some cases, AI can perform tasks better than humans. Particularly when it comes to repetitive, detail-oriented tasks like analyzing large numbers of legal documents to ensure relevant fields are filled in properly, AI tools often complete jobs quickly and with relatively few errors.

### **AI in healthcare.**

The biggest bet on improving patient and reducing costs. Companies are applying machine learning to make better and faster diagnoses. One of the best-known technologies is



are on improving patient outcomes and reducing costs. Companies are applying machine learning to make better and faster diagnoses. One of the best-known technologies is

IBM Watson. It understands natural language and can respond to questions asked of it. The system mines patient data and other available data sources to form a hypothesis, which it then presents with a confidence scoring schema. Other AI applications include using online virtual health assistants and chatbots to help patients and healthcare customers find medical information, schedule appointments, understand the billing process and complete other administrative processes. An array of AI technologies is also being used to predict, fight and understand pandemics such as COVID-19.

#### **AI in business.**

Machine learning algorithms are being integrated into analytics and customer relationship management (CRM) platforms to uncover information on how to better serve customers. Chatbots have been incorporated into websites to provide immediate service to customers. Automation of job positions has also become a talking point among academics and IT analysts.

#### **AI in education.**

AI can automate grading, giving educators more time. It can assess students and adapt to their needs, helping them work at their own pace. AI tutors can provide additional support to students, ensuring they stay on track. And it could change where and how students learn, perhaps even replacing some teachers. AI in finance.

#### **AI in personal finance**

Applications, such as Intuit Mint or TurboTax, is disrupting financial institutions

Applications such as these collect personal data and provide financial advice. Artificial intelligence has the potential to transform all organizations. AI holds the key to unlocking a magnificent future where, driven by data and computers that understand our world, we will all make more informed decisions. These computers of the future will understand not just how to turn on the switches but why the switches need to be turned on. Even further, they may one day ask us if we need switches at all. Although AI cannot solve all your organization's problems, it has the potential to completely change how business is done. It affects every sector, from manufacturing to finance, bringing about never before seen increases in efficiency. As more industries adopt and start experimenting with



change even more widespread and sweeping than the introduction of computing devices. It will change the way we transact, get diagnosed, perform surgeries, and drive our cars. It is already changing industrial processes, medical imaging, financial modeling, and computer vision. We are well on our way to tapping into this enormous potential, and as a result, the future holds better decision-making potential and faster,

**Janhavi Suryawanshi**  
**SE E&TC**



## Automatic Height Measurement

Measuring height helps to show whether a child is growing well (measuring the child's height as they are is an important way to check they are developing as they should be). The research focused on the need to consider a parametric design of height measuring system with the enlightenment of basic design. The material involved for the parametric design of medical measuring under study are ultrasonic sensor, liquid crystal display, medium density fireboard, microcontroller, Arduino board and other accessories

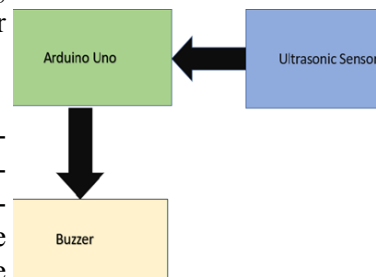

There are several methods used to measure human height. Nowadays, several theories and researches for height measurement methods are presented. People use several machines of scales to measure height.

A new height measurement method of irregular objects is proposed in this paper. In our scheme, we calculate the height with an Ultrasonic Sensor. The experimental results show that the relative error is less than any other, which improves the efficiency and accuracy of height measurement, and it realizes the automation of the measurement process and can satisfy the requirement of real-time.

The system is based on Node MCU and HC-SR04 ultrasonic sensors. The height will be measured using an ultrasonic sensor. Ultrasonic is made up of two round shape components that are ultrasonic speakers. One of them sent a 40kHz sound wave into the air and let it bounce off the solid surface. When it receives the bounce back, the other will try to identify the echo that is created. The entire time required to finish this operation will provide us with the lengths between the sensor and the object. Then this data input will go into Node MCU. Then Node MCU will read it and send it to the LCD Display.

Most of the components, such as the microcontroller, resistors, and wires would be inside of the main body of the drawer. However, the sensor would be on the extending part of the drawer so that the sensor has enough clearance to successfully take a reading to the ground, without any parts of the patient's body obscuring it. The device would be powered on and off through a button on the side of the device. Height-measurement data will also be activated using a side button. The LCD screen on the side of the device would then display the final height-measurement value.

**Advantage:**

- 1 This instrument measure human body without physical contact
- 2 This project has low cost, and is an efficient device to estimate human body size.
- 3 Good measurement in close distance
- 4 This project may be use any where go to various place
- 5 This project can be use any place its is a multi-purpose project
- 6 Handle this project be easily



**Mr,Aakash Jadhav , Mr.Amol Deore , Mr.Sandip Jondhale  
TE E&TC**

## The 5 next trends in electronics

### 1.2D electronics

Interest in the field started with the discovery of graphene, a structural variant of carbon. Carbon atoms in graphene form a hexagonal two-dimensional lattice, and this atom-thick layer has attracted attention due to its high electrical and thermal conductivity, mechanical flexibility and very high tensile strength. Graphene is the strongest material ever tested.

In 2010, the Royal Swedish Academy of Sciences decided to award the Nobel

Prize in Physics to Andre Geim and Konstantin Novoselov for their “groundbreaking experiments” in graphene research.

Graphene may have started this 2D revolution in electronics, but silicene, phosphorene and stanene, atom-thick allotropes of silicon, phosphorus and tin, respectively, have a similar honeycomb structure with different properties, resulting in different applications.

All four have the potential to change electronics as we know it, allowing for miniaturization, higher performance and cost reduction. Several companies around the globe, including Samsung and Apple, are developing applications based on graphene.

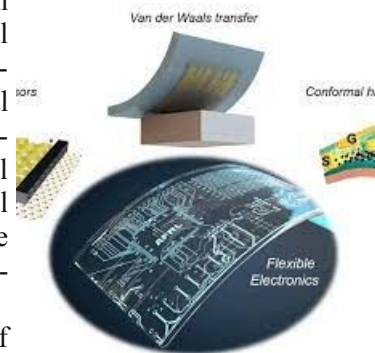

### 2.Organic electronics

The development of conducting polymers and their applications resulted in another Nobel prize in 2000, this time in chemistry. Alan J. Heeger, Alan G. MacDiarmid and Hideki Shirakawa proved that plastic can conduct electricity.

Unlike conventional inorganic conductors and semiconductors,

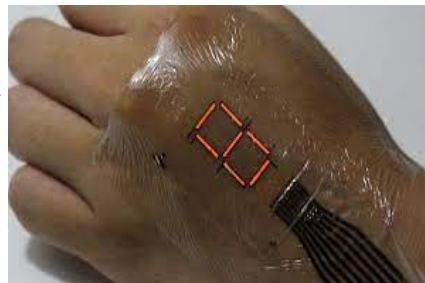

organic electronic materials are constructed from organic (carbon-based) molecules or polymers using chemical synthesis. Organic electronics is not limited to conducting polymers, but includes other organic materials that might be of use in electronics. These include a variety of dyes, organic charge-transfer complexes, and many other organic molecules. In terms of performance and industrial development, organic molecules and polymers can not yet compete with their inorganic counterparts. However, organic electronics have some advantages over conventional electronic materials. Low material and production costs, mechanical flexibility, adaptability of synthesis processes and biocompatibility make organic electronics a desirable choice for certain applications.

Commercially available high-tech products relying on organic semiconductors, such as curved television screens, displays for smartphones, coloured light sources and portable solar cells, demonstrate the industrial maturity of organic electronics. In fact, several high-tech companies, including LG Electronics and Samsung, have invested in cheap and high-performance organic-electronic devices. It is expected that the organic electronics market will grow rapidly in the coming years.

### 3. Memristors

In 1971 Leon Chua reasoned from symmetry arguments that there should be a fourth fundamental electronic circuit-board element (in addition to the resistor, capacitor and inductor) which he called memristor, a portmanteau of the words memory and resistor. Although Chua showed that memristors have many interesting and valuable properties, it wasn't until 2007 that a group of researchers from Hewlett Packard Labs found that the memristance effect can

be present in nanoscale systems under certain conditions. Many researchers believe that memristors could end electronics as we know it and begin a new era of "ionics".

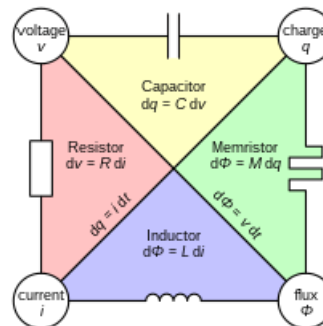



While commonly available transistor functions use a flow of electrons, the memristor couples the electrons with ions, or electrically charged atoms. In transistors, once the flow of electrons is interrupted (for example by switching off the power) all information is lost. Memristors “memorize” and store information about the amount of charge that has flowed through them, even when the power is off. The discovery of memristors paves the way to better information storage, making novel memory devices faster, safer and more efficient. There will be no information loss, even if the power is off. Memristor-based circuits will allow us to switch computers on and off instantly, and start work straight away.

#### 4. Spintronics

Spintronics, a portmanteau word meaning “spin transport electronics”, is the use of a fundamental property of particles known as “electron spin” for information processing. Electron spin can be detected as a magnetic field with one of two orientations: up and down. This provides an additional two binary states to the conventional low and high logic values, which are represented by simple currents. Carrying information in both the charge and spin of an electron potentially offers devices with a greater diversity of functionality.

So far, spintronic technology has been tested in information-storage devices, such as hard drives and spin-based transistors. Spintronics technology also shows promise for digital electronics in general. The ability to manipulate four, rather than only two, defined logic states may result in greater information-processing power, higher data transfer speed, and higher information-storage capacity.

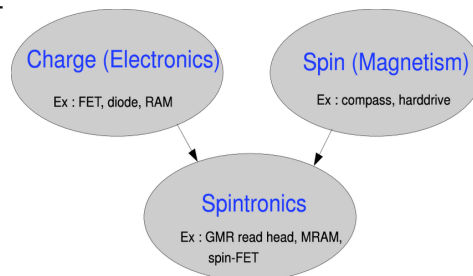

It is expected that spin transport electronic devices will be smaller, more versatile and more robust compared with their silicon counterparts. So far this technology is in the early development stage and, irrespective of intense research, we have to wait a couple of years to see the first commercial spin-based electronic chip.

### **5.Molecular electronics**

The ultimate goal of electrical circuits is miniaturization. Also known as single molecule electronics, this is a branch of nanotechnology that uses single molecules or collections of single molecules as electronic building blocks.

Molecular electronics and the organic electronics described above have a lot in common, and these two fields overlap each other in some aspects. To clarify, organic electronics refers to bulk applications, while molecular-scale electronics refers to nano-scale, single-molecule applications. Conventional electronics are traditionally made from bulk materials. However, the trend of miniaturization in electronics has forced the feature sizes of the electronic components to shrink accordingly. In single-molecule electronics, the bulk material is replaced by single molecules. The smaller size of the electronic components decreases power consumption while increasing the sensitivity (and sometimes performance) of the device. Another advantage of some molecular systems is their tendency to self-assemble into functional blocks. Self-assembly is a phenomenon in which the components of a system come together spontaneously, due to an interaction or environmental factors, to form a larger functional unit.

Several molecular electronic solutions have been developed, including molecular wires, single-molecule transistors and rectifiers. However, molecular electronics is still in the early research phase, and none of these devices has left the laboratory.

**Deore Kiran Vijay  
BE E&TC**

## **External Power Adapters and Chargers: An overview of market trends and forecasts**

As the world becomes increasingly digitally connected, the demand for mobile devices such as smartphones, laptops, media and mobile tablets, desktop computers, wearables, set-top boxes, appliances, etc. is steadily growing. Entertainment devices like smart speakers, digital cameras, handheld video games, etc. are also becoming more popular as young people in developing economies start to use them. All of these devices depend on power adapters and chargers that convert the incoming AC supply voltage to a regulated output that can drive the load device.

### **Revenue Forecasts and Growth Drivers**

According to the Global External Power Adapters and Chargers Market – 2022 report by Wired and Wireless Technologies (WAWT), the total market revenue for these products was estimated at approximately US\$ 9 billion in the year 2021. Annual revenue growth of around 7% in 2021 was driven more by an increase in average selling price (ASP) than by a rebound in demand following the COVID-19 pandemic. The COVID-19 pandemic adversely impacted the overall revenue, both from the supply constraints and delays due to lockdowns and also from a decline in mobile phone demand.

The mobile phones and chargers segment continues to dominate the overall external power adapter and charger market, accounting for 25% of the share in revenue and 32% of the share in volume in 2021. However, its share started to witness a significant decline in both 2020 and 2021, with WAWT predicting a continued decline through the forecast period until the year 2026.

### **Future Trends**

The USB 3.1 Standard, adopted May 2021, extends and improves on the power delivery capability with USB-C connectors and offers several advantages in power delivery (USB PD), some of which are listed below:

Extended Power Range (EPR) has been added that significantly increases the power delivery capability with higher voltages, up to a maximum of

- Programmable and adjustable voltage/power settings have been added, giving greater flexibility for chargers being part of a negotiated power delivery protocol where current and voltage can be adjusted based on requirements, which enables a layer of safety to be added, especially in quick charging applications
- The source and sink devices are interchangeable, i.e. a monitor can now supply power to the laptop
- The protocol is backwards compatible, i.e. < 100W of power can still be delivered with standard USB cables
- The USB-C connector, which is part of the EPR delivery, is symmetrical and easier to use than the Type A connectors.
- The USB-IF (USB Implementers Forum) released their latest USB data transfer specification, USB4™. This is based on the Thunderbolt

		USB 3.1 PD: Summary of some PD Specifications							
		Standard Power Range (SPR)				Extended Power Range (EPR)			
voltage (V)	Typical charging application	fixed voltage		programmable power supply		fixed voltage		adjustable voltage	
		Max I (A)	Max P (W)	V range	Max P (W)	Max I (A)	Max P (W)	V range	Max P (W)
5	headphones	3		3.3 - 5.9		3			
9	smartphones	3		3.3 - 11		3			
15	tablets	3		3.3 - 16		3			
20	laptops	3	15 - 60	3.3 - 21	15 - 60	3	15 - 60		
20	laptops	5 <sup>1</sup>	60 - 100	3.3 - 21	60 - 100	5 <sup>1</sup>	60 - 100		
28 <sup>1</sup>	gaming laptops, laser							↕	↔ 100 - 140
36 <sup>1</sup>	printers, LED TVs, e-							↕	↔ 140 - 180
48 <sup>1</sup>	scooters							↕	↔ 180 - 240

3.0 protocol and will run over the USB-C connectors/cables to allow data transfer rates as high as 40GBps. This positions the USB-C to be a universal connector for data and power in a number of applications

**Greater adoption of Gallium Nitride (GaN) technology:**

GaN-based power devices have several advantages over traditional silicon-based devices, which translate to much improved power conversion efficiencies, higher power densities in a given footprint, and/or cooler adapters due to reduced power lost as heat. An example is Apple’s 140W power adapter for the MacBook Pro laptops. Figure 2, taken from the 2021 GaN Power 2021 report from yole Development, shows the market trend in the adoption of GaN. The consumer application space, which includes power adapters and chargers, is expected to have a CAGR of 69% over the 6-year period from 2020 to 2026.

## Importance Of Electronics In Modern Life

Electronics have become present in every house, and their use has become very versatile and indispensable, electronics are at the heart of human life from the simplest things he uses and ending with the most complex, such as television, radio, digital cameras, cars, airplanes, medical devices, refrigerator, microwave, computers, and many other devices that are not limited, and



electronics are characterized by many advantages, and have some drawbacks, The benefits of electronics in our lives have saved people a lot of time, effort and money, because they mostly use savings systems.

It made people's lives easier, smoother and more vibrant, and reduced distances between nations, such as the use of mobile phones and personal computers. It facilitated communication between individuals, communities and countries, deepened dialogue and approached languages, many of which relied on translation features. You've given people a way to have fun and entertainment, through the online gaming apps you've given people to practice on electronic devices any time they want. It provided an easy way to educate people, and made communication between teacher and student very easy. Developed from the medical process and facilitated the means of treatment for patients, and contributed to the success of medical operations and performed with ease, speed and mastery. Contributed to maintaining security and security and detecting crimes through surveillance cameras.

**Surve Pranjal Devidas**  
**SE E&TC**

## Best Educational Tool

### 1.ChatGPT

(Chat Generative Pre-trained Transformer[2]) is a chatbot developed by OpenAI and launched in November 2022. It is built on top of OpenAI's GPT-3 family of large language models and has been fine-tuned (an approach to transfer learning) using both supervised and reinforcement learning techniques. ChatGPT was launched as a prototype on November 30, 2022, and quickly garnered attention for its detailed responses and articulate answers across many domains of knowledge. Its uneven factual accuracy, however, was identified as a significant drawback. Following the release of ChatGPT, OpenAI's valuation was estimated at US\$29 billion in 2023.



### 2.Mixo.IO

Mixo helps entrepreneurs quickly launch and validate their business ideas. It has an AI-powered builder that can generate a website in any language in seconds from just a brief description of an idea. Mixo also helps to collect customer feedback and grow audiences with integrated subscriber management tools.

Website link- <https://www.mixo.io/>

### 3.Microsoft's Bing ChatGPT:-

#### Pros:

- Access to internet
- Links back to sources
- Up-to-date on current events

#### Cons:

- Limited preview

**Features:**

- 1. OpenAI’s large language model in the GPT-3 and -3.5 series has access to the internet
- 2. Works like a search engine with information on current events
- 3. Price: Free

<https://www.bing.com/>\_

**4. Jasper**

The best chatbot for Business and marketers

**Pros:**

- 50 different writing templates
- Copyediting features
- Plagiarism checker

**Cons:**

- Focuses on written text
- Steep cost

**Features:**

- 1. Uses OpenAI’s GPT-3
- 2. Can summarize texts and generate paragraphs and product
- 3. Descriptions
- 4. Checks for plagiarism and grammar
- 5. Price: Starts at \$49 per month

Like ChatGPT, Jasper also uses natural language processing to generate human-like responses. Jasper even uses the same language model as ChatGPT, OpenAI’s GPT-3, which was created by the AI research company behind ChatGPT.

**4. Socratic By Google**

The best AI chatbot for kids and student

**Pros**

- Free
- Educational

### **Cons**

Doesn't write text  
No desktop version

### **Features:**

- 1.From Google
- 2.Type in any question to generate a response
- 3.Has fun graphics
- 4.Supports scanning worksheet to get a specially curated answer
- 5.Price: Free

If you want your child to also take advantage of AI to lighten their work load, but still has some limits, Socratic is for you. With Socratic, children can type in any question they may have about what they are learning in school and Socratic will generate a conversational, human-like response with fun unique graphics to help break down the concept.

**Sagar Waghchoure**  
**SE E&TC**



## Cyber Security and Challenges

Cyber security is a term of security which is implicated through diversified disciplines, most of them focusing on technical or psychological problems such as computer science, criminology, economics, engineering, information systems, management, medicare, neurophysiology, psychology, sociology, etc. It affords the people with discussions about behaviors and motivations, benefits and consequences about cyber crime and security. Cyber security will be used to represent the security issues of information systems: Cyber security is one of the information system management by individuals or organization codirect end-users security behaviors, on the basis of personal perceived behaviors toward potential security breach in work and non-work environment. The extant study of cyber security explores three main streams: individual behaviors toward information security in non-work setting, employee behaviors toward information security in work setting, and organization information system security policy (ISSP) compliance and the related issues

### Cyber Security Parameters

Cyber security has some of the parameters which are as follows. Figure 1 depicts about the various kinds of cyber security parameters.

- Identify threats
- Identify vulnerabilities
- Access risk explore
- Establish contingency plan
- Respond to cyber security accident
- Establish contingency plan

### Various types of Cyber Attacks

The attacker will expect the procedure to be synchronized in order to contaminate the system. Synchronization of the steps concerned to steal the information directs them to attain what they expect. The hackers will get their result in time, in step and in their line. An organized form of the methods will be used by the attacker or hacker lead to infect the system very easily. The usage of logically organized methods leads them to get more well-organized outputs.

### **Denial of Service Attacks**

DOS is one of the attack where an attacker creates a memory resource or computing too full or too engaged to handle legitimate queries, thus denying legitimate user access a machine.

### **Remote to Local Attacks**

A remote to local (R2L) attack is a kind of attack where an attacker send packets to a machine over networks, then exploits the machine's vulnerability to illegitimately increase local access to a machine. It happens when an attacker who has the capability to send packets to a machine over a network but who does not have an account on that machine develops some vulnerability to achieve local access as a user of that machine.

### **User to Root Attacks**

User to root attacks is a kind of attacks where an attacker initiates with access to a moderate user account on the system and is able to expand vulnerability to grow root access to the system in which the attacker starts out with access to a normal user account on the system and is able to exploit some vulnerability to gain root access to the system.

### **Probing**

Probing is another kind of attack where an attacker scans a network to gather information or discover known vulnerabilities. An attacker with map of machine and services that are available on a network can use the information to notice for exploit.

### **Attacks Detection Strategies**

Attacks Detection Strategies is one of the attack. Modern cyber attack detection systems monitor either host computers or network links to capture cyber attack data. Signature based Approach Signature based approach of mishandling discovery works just comparable to the existing anti-virus software. In this approach the semantic description of an attack is analyzed and details is used to structure attack signatures. The attack signatures are structured in such a way that they can be searched using information in audit data logs produced by computer systems.

### **Signature based Approach**

Signature based approach of mishandling discovery works just compara-

can be searched using information in audit data logs produced by computer systems

### **Cyber Ethics**

Cyber ethics are nothing but the code of the internet. Practicing cyber ethics are good chances to use the internet in a correct and protected way. The below are a few cyber ethics one must follow while using the internet.

**Ethics 1:** To communicate and interact people with each other with the assistance of internet. Instant messages and email make it contact to stay in connect with the family members and friends, share knowledge and information with people among the country with the specific organization and all around the world.

● **Ethics 2:** Internet is measured as world's leading library with information on all the topics in any specific subject area, hence using this information in a proper and legal way is always essential.

● **Ethics 3:** People are not able to operate other persons' mail account with their passwords.

**Ethics 4:** On no account try to send any kind of malware to other's systems and make them fraudulent and damage.

**Ethics 5:** Do not share the personal details to anyone as there is a good opportunity of other persons mishandling the mail account and finally that person must be in a problem.

**Ethics 6:** When the person is online do not pretend to be the other person and never try to make any fake account on some other person as it would become a trouble.

**Sanika Gulave**  
**SE E&TC**

## **Android Smartphones in India Differ From the Rest of the World**

Android is the world's most popular mobile operating system, used by billions of devices made by hundreds of different manufacturers. Although the overall experience remains similar for most users, Google has had to make a series of changes to its Android platform in India following a ruling by the country's competition watchdog. According to the latest reports, Android smartphones in India will receive a version of Google Mobile Services (GMS) i.e. goggle mobilem services that comes with optional Google apps. The new Indian Mobile Application Distribution Agreement (IMADA) between OEMs and Google will only require the installation of the Google Play Store.

- Rather than the 11 key Google apps mandated by the standard agreement in other markets. However, Google will offer a “per-app bounty” to smartphone makers who pre-install any of these 11 apps. The IMADA also differs from other markets in that it doesn't require smartphone makers to include; Google search bar, Google app folder, or Play Store icon on the main screen. Additionally, the agreement will allow Indian users to choose their default search engine during the setup process. Similar to the provision in Europe, with this option expected to be available from Q2 2023.

The changes will only apply to smartphones sold in India. The introduction of these changes is significant as it shows that Google is willing to make adjustments to its products and services to meet the specific needs of different markets. It's a positive development that Google is willing to work with regulators and tailor its offerings accordingly. India is the world's second-largest smartphone market after China, and companies like Google must work with Indian regulators to stay in the market. However, we will see in the future whether the gap between the Asian country and the US technology giant will open up due to these developments.

## 6G Networks: What You Need to Know

So, what exactly is 6G? Is it just another name or marketing catchphrase? The answer is no. As the name implies, 6G technology is the sixth generation of wireless technology that will improve and enhance our current mobile network infrastructure through greater optimization and higher data transfer



speeds. The new technology will use a higher frequency spectrum than 5G and is expected to provide lower latency and higher bandwidth capacities. Essentially, the new technology will improve the performance of current communication standards to such a degree that it will revolutionize the technology industry. With enhanced communication capabilities, we will experience a technological revolution affecting all industries, including healthcare, finance, transportation and education. (Also Read: Into the Future: The Outlook Advances in healthcare will lead to faster diagnostic procedures, allowing doctors to provide prompt and accurate treatment to patients. The finance industry will benefit from low latency and high-speed financial transactions. The transportation industry will also benefit from the technology, as 6G network speeds will enable self-driving cars and other autonomous vehicles to proliferate)

In Telecommunications, 6G is the sixth generation mobile system standard currently under development for wireless communications technologies supporting cellular data networks. It is the planned successor to 5G and will likely be significantly faster. Like its predecessors, 6G networks will probably be broadband cellular networks, in which the service area is divided into small geographical areas called cells.

**Payal Gunjal**  
SE E&TC

## E-Document Diary For College

From a long time in colleges there is a facility that if any staff members or higher authority requires any previous letter or document then office members or dispatch clerk must have to search all the old files, mails and he get that letter. So it takes much more time for finding there-quired letter. In some cases there are chances for loss of any confidential letters.

So, all the staffs suffering from bad condition or from critical condition due to misplace or loss of letters. Hence we did market survey and we get these drawbacks of existing system. So, we plan for the same.

To overcome the problem of existing system we are developing software in which we store all the documents which comes from various authorities just like MSBTE, DTE, AICTE, RHTE, SPPU University etc. If any staff members requires any kind of documents then he/she will get it very quickly. We are providing searching facility we can search by date, by inward, outward number, by authority, by subject. So, it will be easier rather than finding all the mails, files. It is helpful for the colleges. This system is the solution for college or any organization to maintain or track information of all documents, letters etc.

This web based system platform all the jobs that are done in conventional system but here, everything is done in more formal and efficient manner. This system provides following facilities:

- 1) Searching all document within less time which avoid wastage of time to search any old documentation we have provided various options such as search by date, letter number, inward number, outward number, authority by subject.
- 2) Provide access of documents to multiple people as we have provided various logging such as Principle, HOD, and Staff and Clerk and also we have provided proper authentication to each user account.

3) Provide access of documents to multiple people as we have provided various logging such as Principle, HOD, and Staff and Clerk and also we have provided proper authentication to each user account.

### Advantages

- I. Easy searching of documents.
- II. Proper authentication to accounts.
- III. In future if any confidential letter is lost then we will get it easily by this software.
- IV. It will be time saving process.

Implementation is the stage where the theoretical design is turned into a working system. It includes all those activities that takes place to convert from old system to the new one.

After careful analysis the system has been identified to have the following modules:

- Login Module
- Admin Modle
- HoD Module
- Staff Module
- Clerk Module

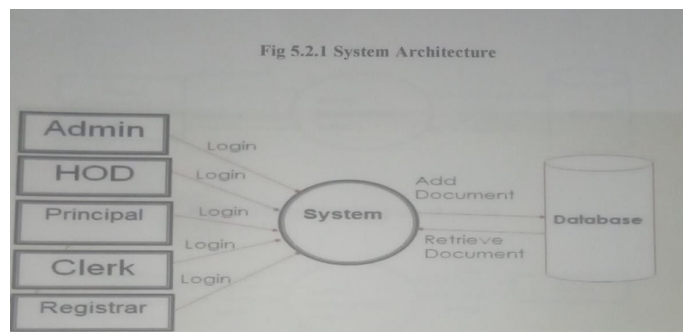

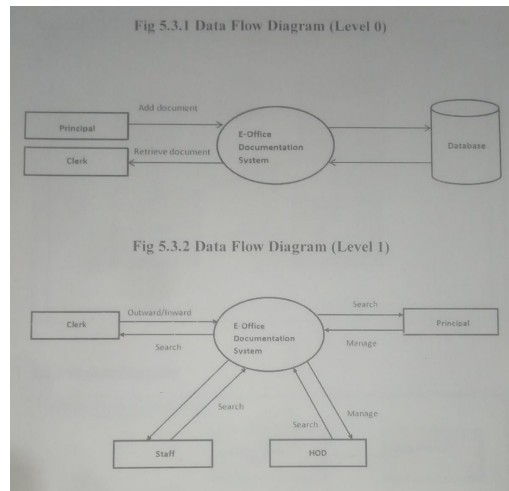

### Login Module

Proper user authentication makes the system more secure and able to assign rights as per user. In addition to this, we have implemented the logins for different users like Admin module, HOD module, Staff module, and Clerk module.

### Admin Module

This module is developed for all overall administration and control of software. It having many inbuilt facility for master settings. It having following facility:

- Register new User
- Prepare all masters used in system.

### HOD Module

This module design for each college head of dept. Integrated module which having facility to retrieved documents as per search pattern below.

- Search by Authority
- Search by Date
- Search by Subject



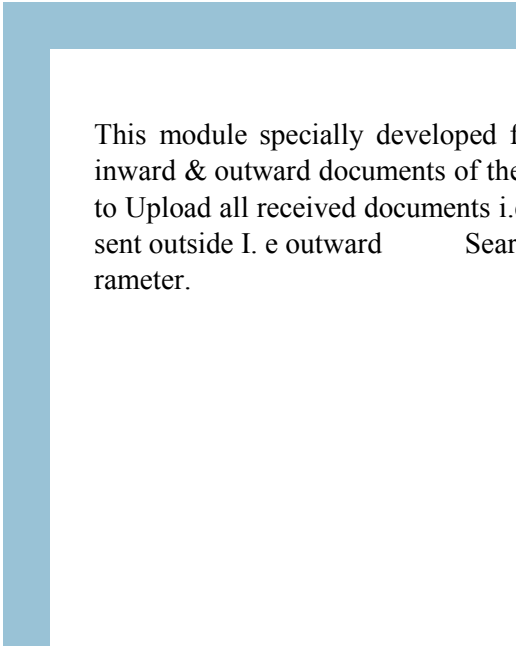

This module specially developed for college clerk who handle all inward & outward documents of the college. Clerk also have facility to Upload all received documents i.e inward , Upload all documents sent outside I. e outward Search the documents by search parameter.

**Chavan Nilam**  
**SE E&TC**



## Robot creates physical paintings without Human Input



AI-generated and robotically created, are these paintings the fine art of the future?

Robohood Inc, an art and tech start-up specialising in artificial intelligence and robotics, says it has created the world's first AI-robotic technology that enables users to create physical paintings from an idea to canvas without human involvement.

The technology uses stable diffusion, a deep-learning, text-to-image model primarily used to generate detailed images guided by a text prompt. And Robohood combined this novel neural network with its software that renders and brush-paints them with robotic manipulators.

The system, called the Robotic Art Studio, uses a variety of painting techniques by calculating each brush stroke and delicately mixing colours straight on to various surfaces. The results are "fine art pieces that possess a unique and cohesive style".

In fact, E&T asked Robohood to create two pieces of bespoke artwork using the technology, one depicting the neural network's interpretation of 'engineering' and the other 'technology'.

"While generating these images, we deliberately chose to depict human-like motifs," Robohood says of the painting. "Our aim was to emphasise that engineering and technology are an integral part of human life, and to dispel the notion that robots will harm humanity. **Vaishnavi Mahajan**

**E&TC (SE)**

## E-Health Monitoring System

The e-health system, described in this paper, will be use for monitoring of patients' vitalphysiological data. It is composed of three modules: web, mobile and Smart TV module, which cover the essential features for a remote monitoring healthcare system. The system can collect required vital data and make them visible to doctors. Doctors can act upon them (suggest or modify the therapy for example). Additional functionalities like generating and displaying a group overview chart having one data point for each patient, are also implemented.

To ensure compatibility with other systems, we are using Open m-Health platform for data collection and visualization. All modules use common database (MS SQL). The mobile and Smart TV application use web services for interaction with database. Web application is accessible from every device that has Internet connection. As far as for mobile and Smart TV application, it can be downloaded and installed on appropriate user devices.

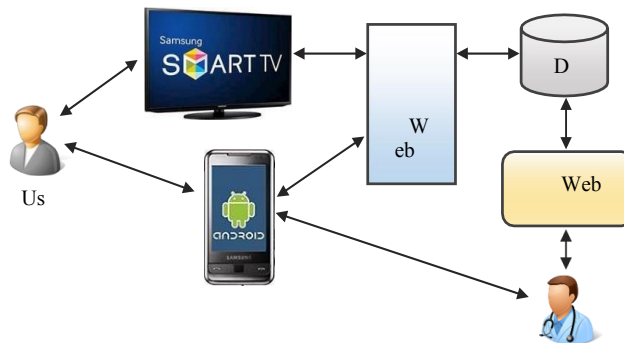

**Web application** has two type of users: patients and doctors. Each patient has access to his own profile. Patient can see medications and dosages prescribed by doctors, as well as some information, notes and advices. He can insert, on a daily basis, measured values for his controlled parameters, like: hart rate, bodytemperature, blood pressure, blood sugar, current weight etc.

Send internal messages to the patients. They can also view the data entered by patients and refer to their vital parameters. Web-application allows two types of data presentation modes: table and graphical. Doctors can use this data within the decision process for prescribing new therapy for the patient, if necessary.

**Mobile application** Is the second part of the proposed system. It is developed In Eclipse using Java programming language. The mobile application has the same functionality as the web application, which allows access to patients' data from anywhere and anytime.

**Smart TV application** is developed using Samsung Smart SDK. It can be used by patients as a reminder for their daily activities, like taking medications on time or going to medical appointment. Smart TV application shows notifications 15 minutes or 1 hour before some activity (depending on the activity type). This application was designed with the idea that a lot of people, while staying at home, are watching TV. So, using the Smart TV platform for creating a reminder application would be an ideal solution

**User Interface System** Taking into account that most of the patients are elderly people, a great deal was putted on user interface design. After extensive analyses on other similar medical applications, and design recommendations proposed in different research studies, a GUI for web, mobile and smart TV applications was designed. Large font size, easy readable typeface, colour contrast, and sufficient blank spaces among the text and graphical items on the screen, were applied for the graphical output optimization. Elderly people can be easily confused if they need to perform a number of operations to get some information. Having this fact in mind, the system was designed to reach the desired information in a fewer steps as possible. Considering the fact that very often the elderly are not able or willing to enter a lot of information by typing, the interface is designed so only important information need to be entered (e.g. measured values, medication, dosage etc.)

Access to the system have all users who already have a profile in the system. Creation of user profiles and managing some general information is responsibility of the administrator.

values for their controlled parameters. He can select one of the controlled parameters, after which an appropriate form for inserting values is presented. Patient can also choose if he wants to write some notes to the doctor

**Fig.3.** a). Mobile application dashboard for patient b) Inserting values for a specific parameter Patient receives notifications about medications, or some appointment, using Smart TV applications. It is very important for the patient to take the prescribed medication on time, so the notification window will stay active until the patient turned it off.

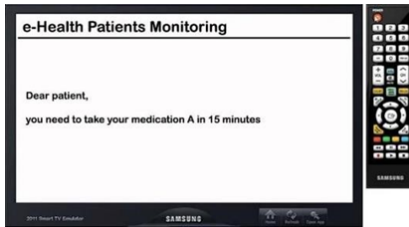

### Smart TV notification

Doctors can check patients' medical record, can suggest therapy or prescribe medications using web-based application or a mobile application. After successful login action, doctors can select a desired activity from the application dashboard. After selecting the patient, from a patient list,

doctors also patient can be presented as a table or a graphic.

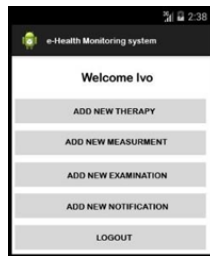

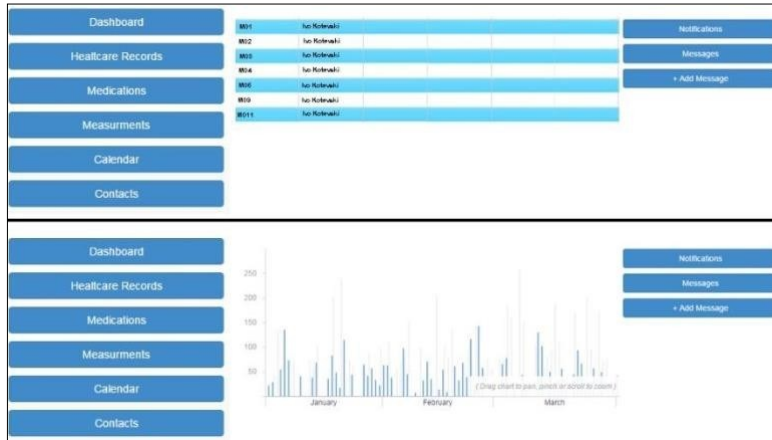

Overview of patients' medical record

Rani Bagdane  
SE E&TC

## Flying Cars

In recent years, our surface transportation infrastructure is suffering from overuse, extreme traffic congestion, and roadway disrepair. Instead of following the traditional infrastructure expansion policy, current transportation research focuses on developing innovative and novel solutions to the aforementioned issues. Current pathways to overcoming these issues include the gradual transition toward a number of emerging transportation technologies such as, autonomous motor vehicles for human transport, as well as unmanned aerial vehicles (UAV's) and "drone" technologies for surveillance and package deliveries. However as a long-term solution, transportation scientists are also investing in the once-seemingly futuristic notion of flying car technology.

So, Indian skies could see flying cars in the near future. Companies like Vinata Aeromobility and The ePlane company are breaking new ground in the country with their eVOTL (electric vertical take off and landing vehicles) technology. The ePlane company started by IIT-Madras professor Satya Chakravarthy and his student Pranjal Mehta, aims to convert rooftops into landing spots for eVOTL aircrafts.

In this context, the ongoing evolution of flying cars will have profound impacts upon various policies and standards that govern future development, test, evaluation, validation, and deployment of the technology. Forecasting existing regulations and establishing appropriate incentives that will serve to standardize and sustain a full-scale flying car trans-





In fact, flying cars are real and they could shape how we commute, work and live in the coming decades. Advances in battery energy density, materials science and computer simulation have spurred the development of a range of personal flying vehicles, from electric gliders to fixed wing craft and quadcopter drones.

VTOL (Vertical Take – off and Landing) or electric power technologies being developed and applied to make flying cars.

Flying cars can take a much more direct route from point A to point B. This means less fuel is required and the journey times are much quicker as a result when compared to a journey on land. Flying cars aim to provide green, safe, convenient and fast transportation in urban areas.

**Roshani Desale**  
**BE E&TC**







## Robot Vacuum Cleaner

Things to remember before buying a robotic vacuum cleaner. Buying a Robotic Vacuum Cleaner for your home can be a pretty challenging task. It can be such a hassle to decide what type of robot cleaner you want, which is the best suitable product for your home which also comes at an easy budget? Moreover, it can be a mind-boggling process to go through so many product recommendations, reviews, YouTube videos and many more. Quite a few times, not many of us are not well aware about the gadgets we want to buy. And again, since there are so many options out there, it can get very overwhelming to reach a conclusion. But, you don't have to worry about it anymore because we have curated a list of checkboxes for you that you need to check before buying a robotic vacuum cleaner.

### **Following are a few suggestions:**

#### **Battery Power:**

A good battery power will ensure a good run-time. The batteries can vary from 2600mAh, 3000mAh to 3200mAh. More the battery power, better the working time. A typical 2600mAh can give a good 90-120 mins of working time. 3000mAh can give around 120-140 mins and 3200mAh can give you around 120-160 of working time. A product's battery consumption also depends on the technology that supports the product. Better the technology, more the power consumption. Also, battery consumption may also vary due to the simultaneous function such as the wi-fi connection to the product.



**Low Suction (Baby Mode):**

In this mode, the suction power ranges around 800pa. It is called Baby Mode because it makes minimum noise and it cleans the home quietly.

**Medium Suction:**

In the medium suction mode, the suction power ranges from 1800-1900pa. Medium suction mode is preferred as an ideal mode as the robot cleans the house using efficient power and suction. Especially for a big home, medium suction mode does the work proficiently.

**High Suction:**

In this mode, the suction power ranges around 3000pa. High suction mode tends to clean even the micro particles and pet hair efficiently. The only drawback of this mode is that the robot will drain its power easily.



**Janavi Ahire**  
**SE E&TC**

## Software-Defined Networking

Software-Defined Networking (SDN) is an approach to networking that uses software-based controllers or application programming interfaces (APIs) to communicate with underlying hardware infrastructure and direct traffic on a network. This model differs from that of traditional networks, which use dedicated hardware devices (i.e., routers and switches) to control network traffic. SDN can create and control a virtual network – or control a traditional hardware – via software. This model differs from that of traditional networks, which use dedicated hardware devices (i.e., routers and switches) to control network traffic. SDN can create and control a virtual network – or control a traditional hardware – via software. While network virtualization allows organisations to segment different virtual networks within a single physical network, or to connect devices on different physical networks to create a single virtual network, software-defined networking enables a new way of controlling the routing of data packets through a centralised server.

### Why is Software-Defined Networking important?

SDN represents a substantial step forward from traditional networking, in that it enables the following:

- Increased control with greater speed and flexibility: Instead of manually programming multiple vendor-specific hardware devices, developers can control the flow of traffic over a network simply by programming an open standard software-based controller. Networking administrators also have more flexibility in choosing networking equipment, since they can choose a single protocol to communicate with any number of hardware devices through a central controller.
- Customizable network infrastructure: With a software-defined network, administrators can configure network services and allocate virtual resources to change the network infrastructure in real time through one centralised location. This allows network administrators to optimise the flow of data through the network and prioritise applications that require more availability.
- Robust security: A software-defined network delivers visibility into the entire network, providing a more holistic view of security threats. With the proliferation of smart devices that connect to the internet, SDN offers clear advantages over traditional networking. Operators can create separate zones for devices that require different levels of

The key difference between SDN and traditional networking is infrastructure: SDN is software-based, while traditional networking is hardware-based. Because the control plane is software-based, SDN is much more flexible than traditional networking. It allows administrators to control the network, change configuration settings, provision resources, and increase network capacity — all from a centralised user interface, without the need for more hardware. There are also security differences between SDN and traditional networking. Thanks to greater visibility and the ability to define secure pathways, SDN offers better security in many ways. However, because software-defined networks use a centralised controller, securing the controller is crucial to maintaining a secure network.

#### **How does Software-Defined Networking (SDN) work?**

- Here are the SDN basics: In SDN (like anything virtualized), the software is decoupled from the hardware. SDN moves the control plane that determines where to send traffic to software, and leaves the data plane that actually forwards the traffic in the hardware. This allows network administrators who use software-defined networking to program and control the entire network via a single pane of glass instead of on a device by device basis. There are three parts to a typical SDN architecture, which may be located in different physical locations: Applications, which communicate resource requests or information about the network as a whole; Controllers, which use the information from applications to decide how to route a data packet; Networking devices, which receive information from the controller about where to move the data. Physical or virtual networking devices actually move the data through the network. In some cases, virtual switches, which may be embedded in either the software or the hardware, take over the responsibilities of physical switches and consolidate their functions into a single, intelligent switch. The switch checks the integrity of both the data packets and their virtual machine destinations and moves the packets along.

**Abhisheek Bawa**  
BE E&TC



Appointments	Services	Current	Missed Appointments
<p>2024-09-05 09:00 Dr. A. K. Patil</p> <p>2024-09-10 10:00 Dr. A. K. Patil</p> <p>2024-09-15 11:00 Dr. A. K. Patil</p>	<p>01-01-2024 Dr. A. K. Patil</p> <p>01-01-2024 Dr. A. K. Patil</p> <p>01-01-2024 Dr. A. K. Patil</p> <p>01-01-2024 Dr. A. K. Patil</p>	<p>01-01-2024 Dr. A. K. Patil</p> <p>01-01-2024 Dr. A. K. Patil</p> <p>01-01-2024 Dr. A. K. Patil</p> <p>01-01-2024 Dr. A. K. Patil</p>	<p>01-01-2024 Dr. A. K. Patil</p> <p>01-01-2024 Dr. A. K. Patil</p> <p>01-01-2024 Dr. A. K. Patil</p> <p>01-01-2024 Dr. A. K. Patil</p>

**SNJB's Late Sau. Kantabai Bhavarlalji Jain  
College of Engineering , Chandwad  
(Accredited with NAAC 'A' Grade)**